

Guaranteed by the
5-2-1
promise

5 years warranty on stainless cabinet (parts only)
2 years warranty on wash pump (parts and labour)
1 year parts and labour warranty

GL Premium Glasswasher

The high efficiency, high performance multi-cycle glasswasher also suitable for light duty dishwashing.

Unique one touch controls allow the operator to start a one, two or three minute cycle with one touch of the ergonomically positioned upper controls.

Water consumption is less than 2 litres of hot water per cycle, regardless of cycle time. With selectable cold final rinse, a precision peristaltic detergent injector and long cycle options the Washtech GL is suitable for busy bars and coffee shops, including those serving sandwiches and pastries etc.

FASTCLEAN features including double filtration, L shape wash tank, stainless steel arms with removable end caps, removable rack slide, flush front and 150mm legs - all make the GL easy to keep clean.

Insulated door and front for sound and heat reduction also ensure cool working surfaces.

The Washtech GL is easy to install with 500mm wide cabinet, 15amp power requirement with cordset fitted, 150mm legs and water supply hoses included.

Supplied with one glassrack, one plate holder insert plus one cutlery container.



Over 25 years Washtech has earned the position of Australasia's leading wash equipment manufacturer by providing robust, reliable machines designed for ease of service and years of effective, efficient operation.



ISO 9001 certified and audited since 1993 - our equipment complies with all local hygiene, electrical and plumbing regulations including WATERMARK.



Washtech products are supported nationwide by the MOFFAT Service Network to ensure long term access to parts and after sales support and service including preventative maintenance programmes.



In line with policy to continually develop and improve its products Moffat reserves the right to change specifications and design without notice.

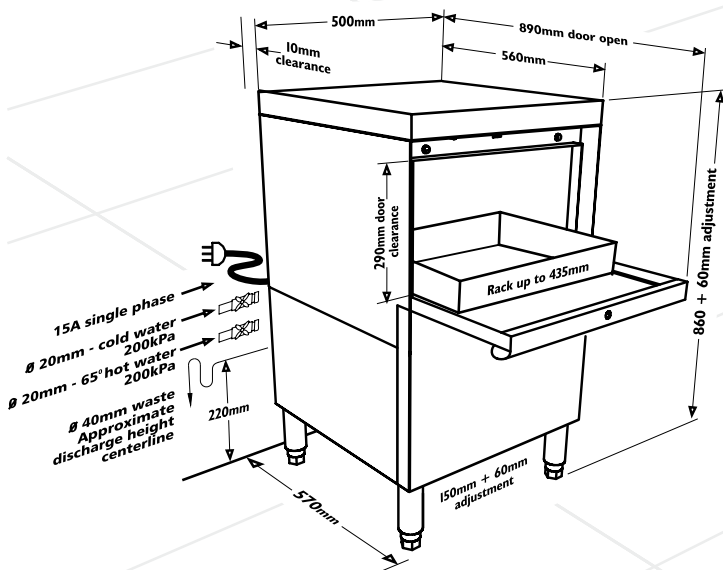

Installation drawing and detail overleaf.



www.moffat.com.au

24 HOUR SERVICE
1800 622 216

REPLACEMENT PARTS
1800 337 963

Australia Moffat Pty Limited

Victoria/Tasmania
740 Springvale Road
Mulgrave, Victoria 3170
Telephone 03 9518 3888
Facsimile 03 9518 3833
Email vsales@moffat.com.au
www.moffat.com.au

New South Wales
Telephone 02 8833 4111
Email nswsales@moffat.com.au

South Australia
Telephone 03 9518 3888
Email vsales@moffat.com.au

Queensland
Telephone 07 3630 8600
Email qldsales@moffat.com.au

Western Australia
Telephone 08 9202 6820
Email bgarcia@moffat.com.au

Effective February 2009

WASHTECH® GL

GL Premium Glasswasher

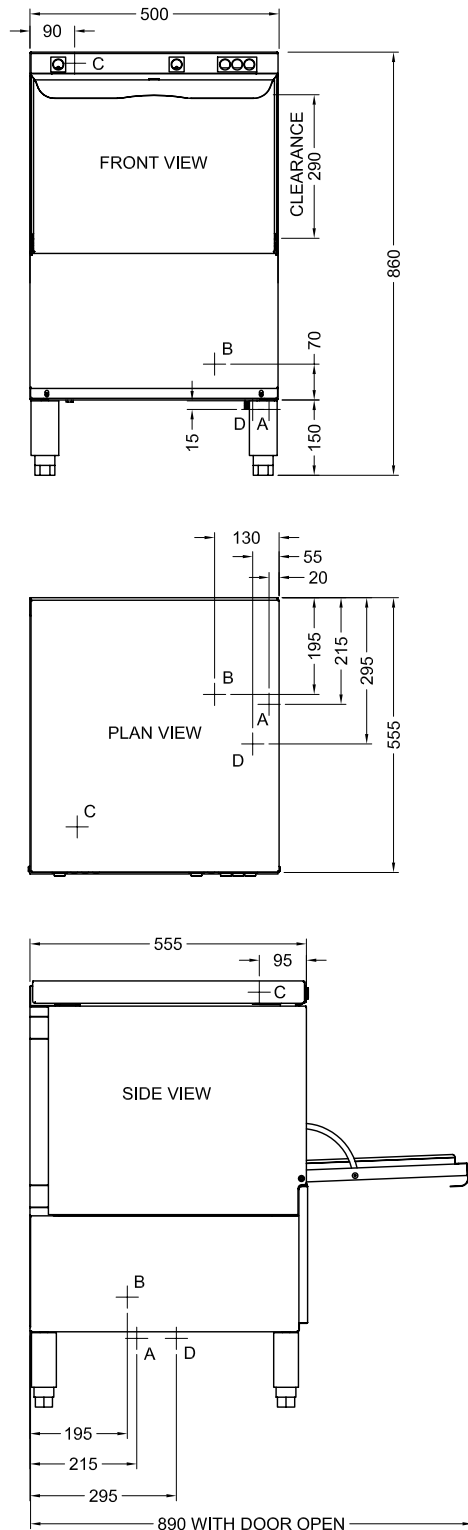

ALL DIMENSIONS IN MILLIMETRES

- | | |
|---|-------------------|
| A | HOT WATER SUPPLY |
| B | WASTE |
| C | POWER SUPPLY |
| D | COLD WATER SUPPLY |

ENSURE DUAL CHECK VALVE IS LOCATED AT THE WATER SUPPLY ENTRY POINT.

Installer must be suitably qualified and ensure compliance with all local codes and standards including AS/NZS3500.1. Failure to comply even partially with installation instructions may void the warranty. Install machine on sound waterproof self-draining floor, with adjacent surfaces sealed against water and/or light steam. Use the adjustable feet to level the machine. Allow room for detergent to one side of machine or in adjacent cupboard. 20 litre container requires about 450H x 250W x 350D but smaller containers are available from many suppliers.

Water Supply

Hot water temperature	65°C ± 5°C
Connection	20 mm (3/4" BSP) male
Pressure	200 kPa = 30 psi
Flow rate minimum	20 litres per minute
Hot water consumption	2 litres per cycle
Cold water supply	Same pressure & flow as hot
Cold water consumption	1.5 litres per cycle approx
Backflow prevention	Dual Check Valves supplied

Pressure limiter may be required. Don't use small diameter plastic supply lines. FLUSH supply line before connection. Connect supplied DCV to water supply. Poor quality supply or excessive water hardness may affect performance or damage machine - filtration and/or softening is recommended. Optional rinse booster pump available for very low pressure.

Waste

40mm gravity drain - refer to point B in the installation diagram - run waste directly behind the machine or through base.

Power

Electrical supply required is 15A 240V 50Hz via switched outlet adjacent to machine, which is supplied with cordset including 15A plug.

Detergent

Insert pump inlet hose into container of commercial low foam detergent. Open machine door and switch machine on. Press and hold detergent prime switch behind front cover until chemical flows into machine. Commercial detergents can be hazardous - read instructions and handle with care.